

Heated washer jets,

from October 1997

For alternatives to relay and fuse positions as well as multi-pin connector wiring-see "Fitting locations" section.

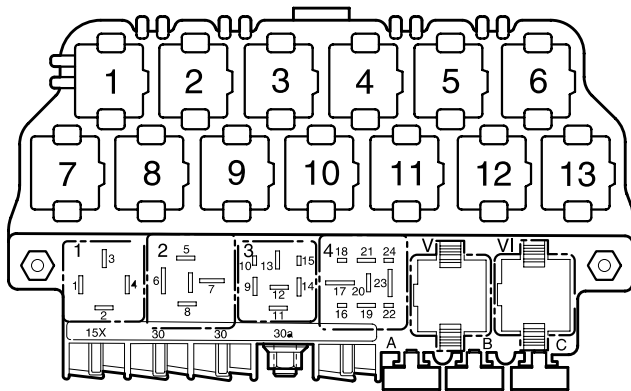

97-14163

Relay locations on 13 position additional relay carrier, above relay plate:

Relay locations on relay plate:

2 X contact relief relay (18)

Fuse colours

- 30 A – green
- 25 A – white
- 20 A – yellow
- 15 A – blue
- 10 A – red
- 7.5 A – brown
- 5 A – beige
- 3 A – lilac

Note:

The number in brackets behind the part designation denotes the control number on the housing.

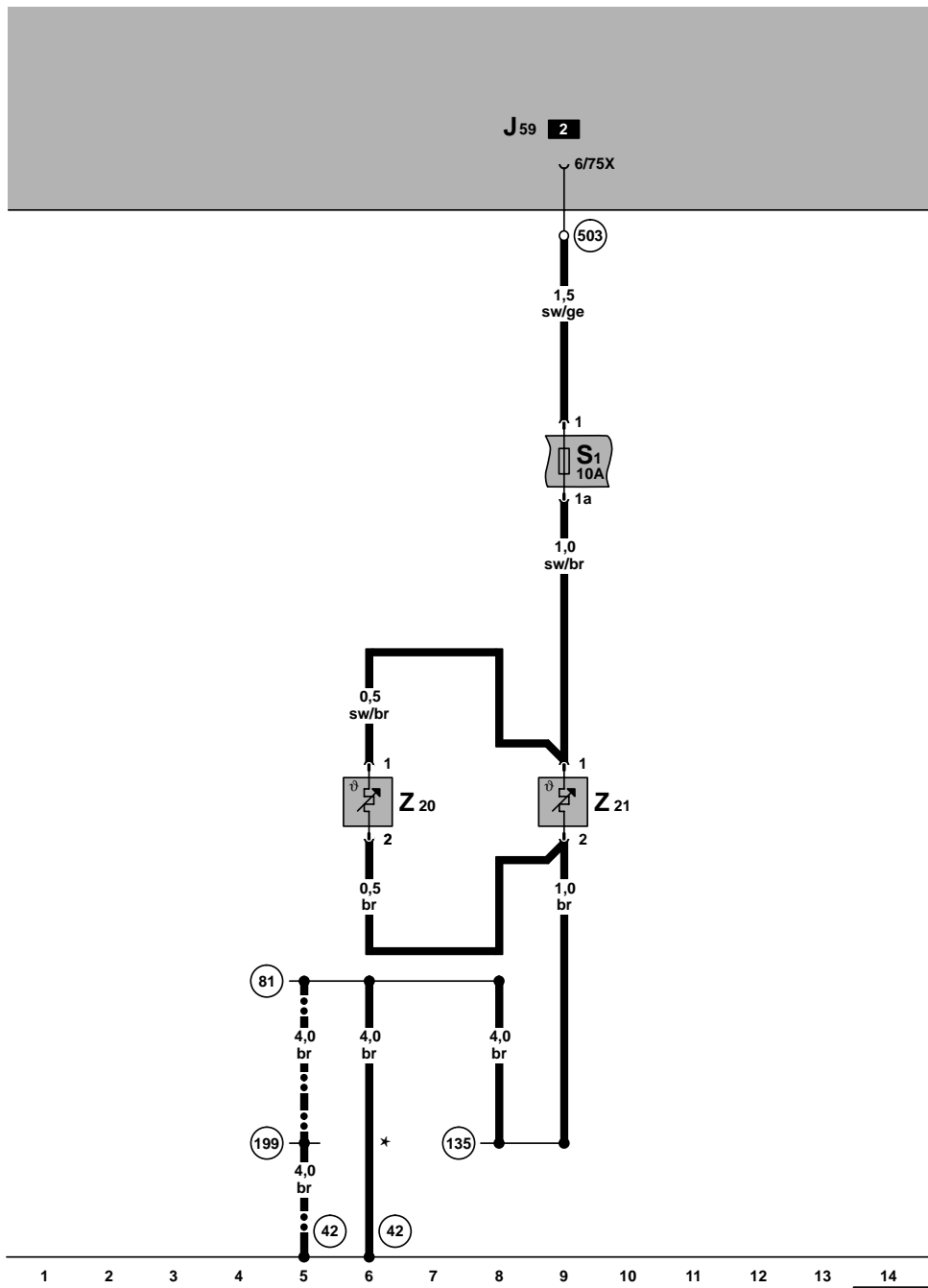

Heated washer jets

- J59 - X contact relief relay
- S1 - Fuse in relay plate fuse box
- Z20 - Heater element, left washer jet
- Z21 - Heater element, right washer jet

- (42) - Earth point on the steering column
- (81) - Earth connection -1-, in dash panel wiring harness
- (135) - Earth connection -2-, in dash panel wiring harness
- (199) - Earth connection -3-, in dash panel wiring harness
- (503) - Screw connection (75x), on relay plate

- * - For vehicles from May 1998
- - For vehicles up to April 1998 only

ws = white
 sw = black
 ro = red
 br = brown
 gn = green
 bl = blue
 gr = grey
 li = lilac
 ge = yellow
 or = orange

1 2 3 4 5 6 7 8 9 10 11 12 13 14

97-26886