



# Technical Bulletin

## Vehicle Delivery Information

---

Wiper arm contact angle	
Driver side	0°/*-3°
Passenger side	0°
Rear wiper	+3°
Tolerance	±2°

\*Wiper blade with plastic spoiler

- Remove adjustment tool and install wiper blades.

**For Warranty claims use the following:**

**Part Identifier: 9225**

**Labor Operation: 9225510 15 TU**



# Technical Bulletin

## Vehicle Delivery Information

Subject: **Wiper Blades, Skipping**

Group: **92**

Number: **95-03**

Date: **Sept. 5, 1995**

Model(s): **Golf, GTI, Jetta**

1996 ►

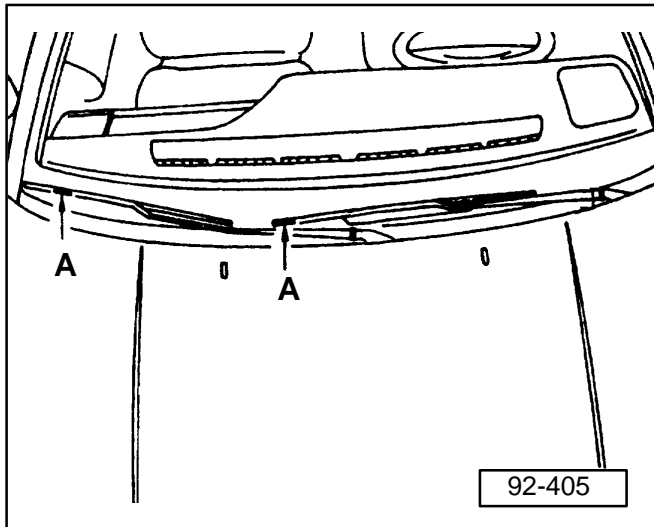

### Condition

Complaint of windshield wipers jerking or skipping across the windshield can be caused by an incorrect contact angle of the wiper arms.

### Service

It is important to check (and adjust if necessary), the positioning and contact angle of the wiper arm as described in the "Technicians Guide" from the 1996 Volkswagen Delivery Satisfaction System.

Adjust the wiper arms using the following steps:

- ◀ – Set wiper arms to rest position.
- Loosen wiper arms and adjust blades to markings **-A-** on windshield.
- Tighten wiper arms.
- Remove wiper blade.
- ◀ – Insert wiper arm **-2-** into wiper arm adjustment tool 3358 and secure with retaining bolt **-3-**.
- Apply 24 mm wrench **-1-** to the adjustment tool and twist **-arrows-** wiper arm **-2-** until the correct angle is attained according to the table below.
- Loosen retaining bolt **-3-**, remove wiper arm **-2-** from adjustment tool then reinstall and recheck.
- Check setting using table on page 2. If necessary, the setting and checking procedure should be repeated until specified value is attained.

