

Trailer towing,

from October 1997

For alternatives to relay and fuse positions as well as multi-pin connector wiring-see "Fitting locations" section.

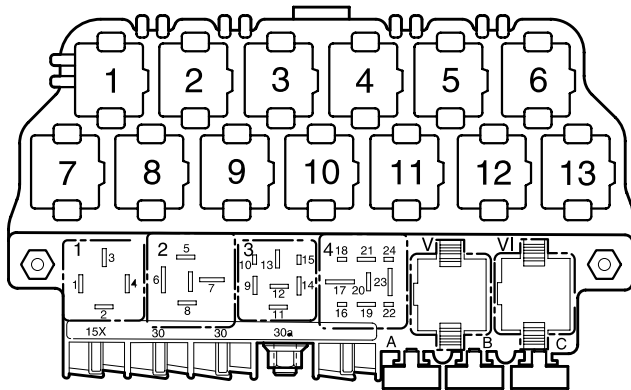

97-14163

Fuse colours

- 30 A – green
- 25 A – white
- 20 A – yellow
- 15 A – blue
- 10 A – red
- 7.5 A – brown
- 5 A – beige
- 3 A – lilac

Rear left turn signal, left reversing light, left tail light, brake light, rear fog light

- F4 - Reversing light switch
- L46 - Rear fog light bulb
- M6 - Turn signal bulb, rear left
- M16 - Reversing light bulb, left
- M21 - Brake and tail light bulb, left
- T5h - 5-pin connector, near lower left A pillar, woven into wiring harness
- T6a - 6-pin connector
- T10 - 10-pin connector, orange, in protective housing for connectors, left in plenum chamber

- (50) - Earth point, on left luggage compartment
- (86) - Earth connection -1-, in rear wiring harness
- (B182) - Connection (RL), in interior wiring harness ***
- (W1) - Positive (+) connection (54), in rear wiring harness
- (W4) - Connection -1- (rear fog light), in rear wiring harness
- (W6) - Connection (left turn signal), in rear wiring harness
- (W13) - Connection (58L), in rear wiring harness

*** - For vehicles from August 1998
 - - - - For vehicles up to July 1998 only

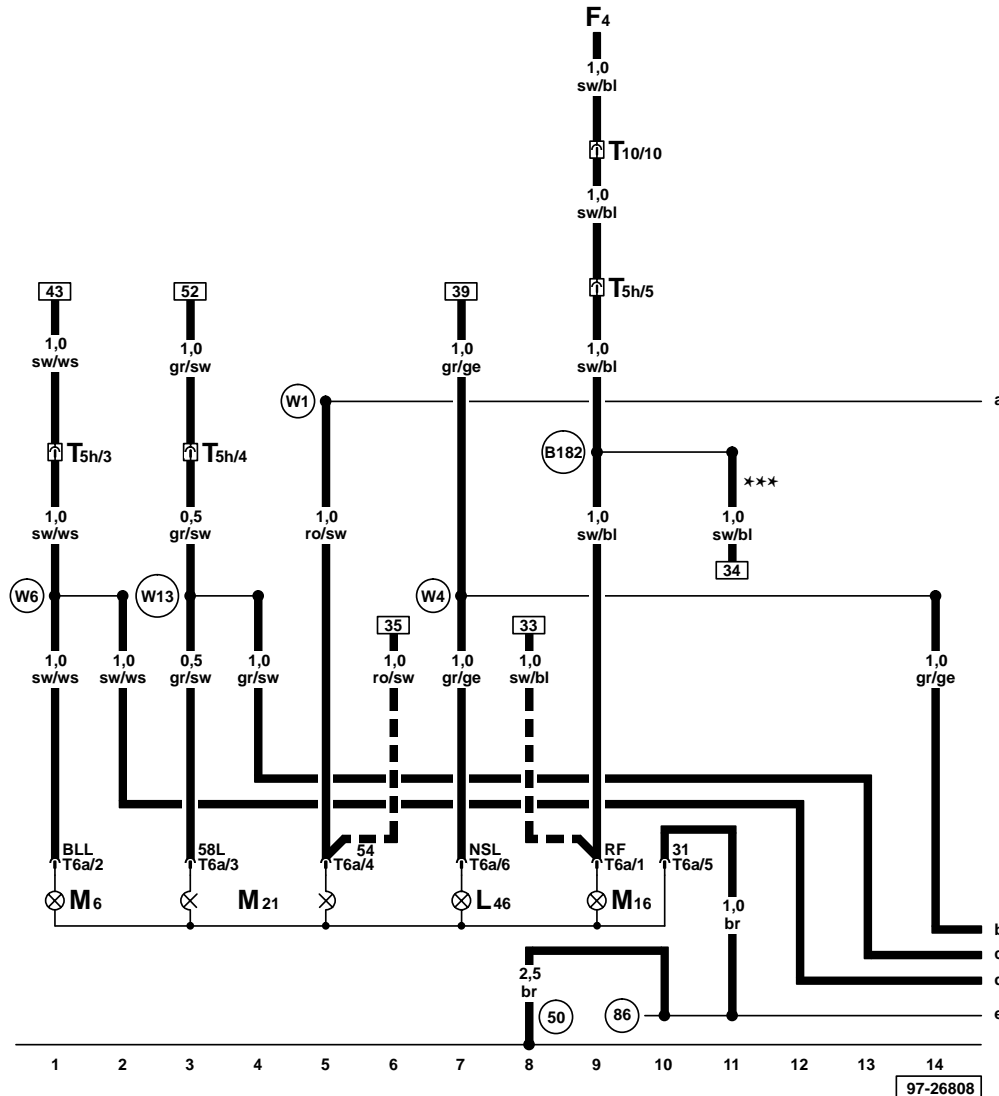

97-26808

Trailer towing socket, rear fog light cut-off

- D - Ignition/starter switch
- F216 - Rear foglight cut-out, contact switch, in trailer towing socket
- S235 - Fuse in fuse holder
- T3 - 3-pin connector
- T5a - 5-pin connector, pink, left C pillar coupling station
- T13 - 13-pin connector
- U10 - Trailer socket

- (98) - Earth connection, in tailgate/boot lid wiring harness
- (501) - Screw connection -2- (30), on relay plate
- (A32) - Positive connection (30), in dash panel wiring harness
- (A98) - Positive connection -4- (30), in dash panel wiring harness
- (B150) - Positive connection -2- (30a), in interior wiring harness**
- (W25) - Connection -2- (rear fog light), in rear wiring harness

- ** - For vehicles with a 12 V socket in luggage compartment only
- .-.- - Only on Golf

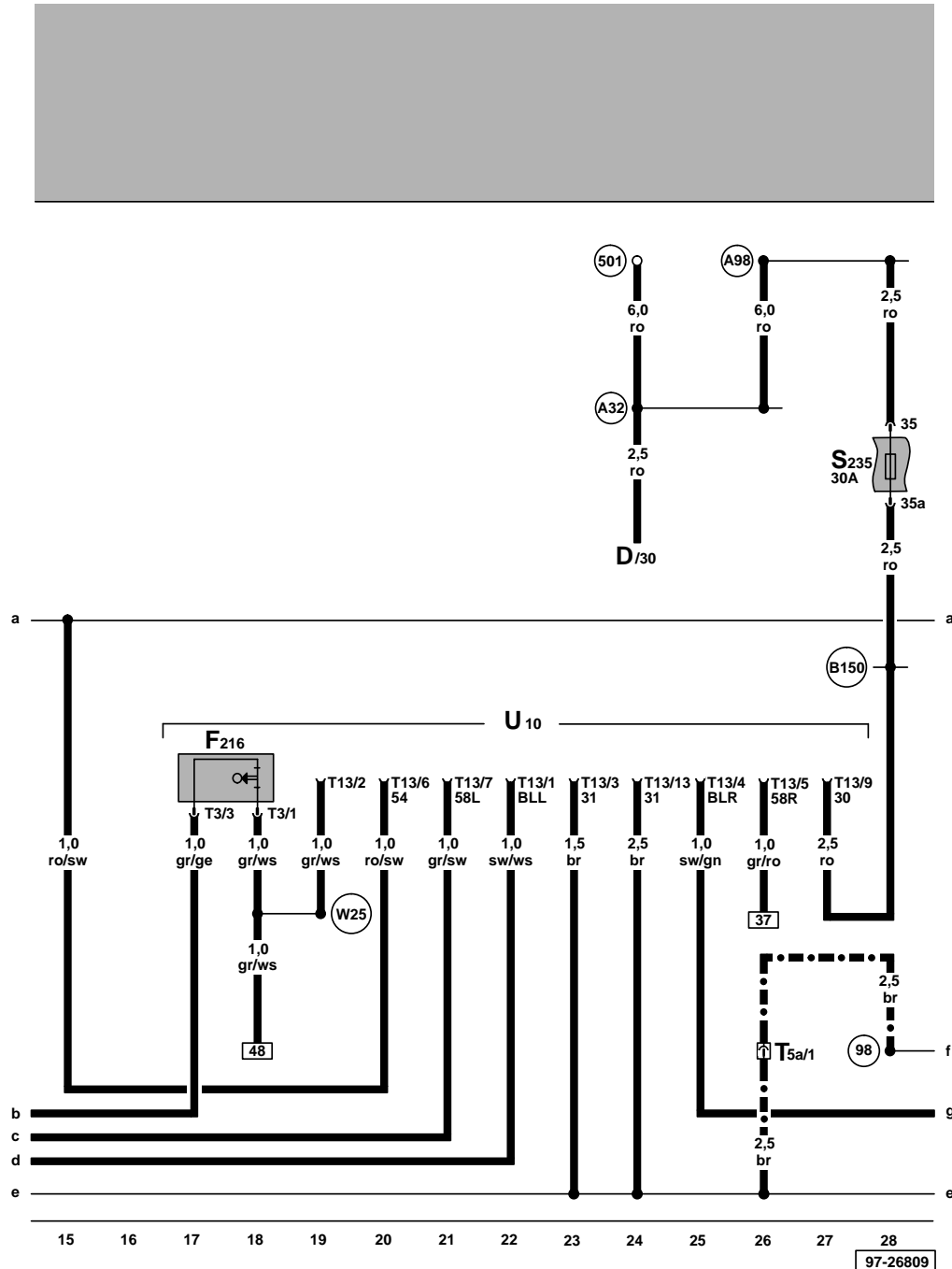

ws = white
 sw = black
 ro = red
 br = brown
 gn = green
 bl = blue
 gr = grey
 li = lilac
 ge = yellow
 or = orange



Rear right turn signal, right tail light, right brake light, Hi-level brake light, right reversing light

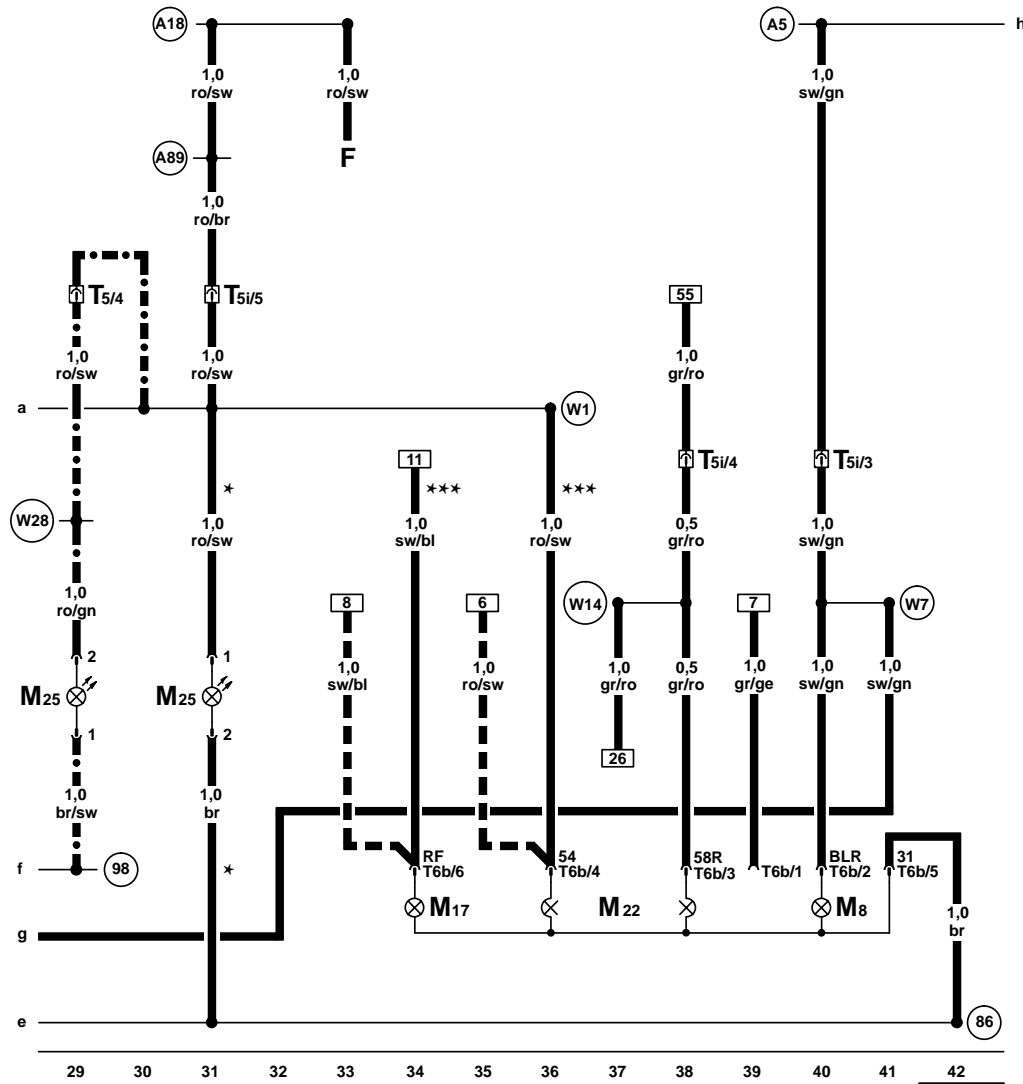

- F - Brake light switch
- M8 - Turn signal bulb, rear right
- M17 - Reversing light bulb, right
- M22 - Brake and tail light bulb, right
- M25 - High level brake light bulb
- T5 - 5-pin connector, black, left C pillar coupling station
- T5i - 5-pin connector, near lower left A pillar, entwined in wiring harness
- T16b - 6-pin connector
- (86) - Earth connection -1-, in rear wiring harness
- (98) - Earth connection, in tailgate/boot lid wiring harness
- A5 - Positive (+) connection (right turn signal), in dash panel wiring harness
- A18 - Connection (54), in dash panel wiring harness
- A89 - Connection (54), in dash panel wiring harness
- W1 - Positive (+) connection (54), in rear wiring harness
- W7 - Connection (right turn signal), in rear wiring harness
- W14 - Connection (58R), in rear wiring harness
- W28 - Positive connection -2- (54), in tail light wiring harness
- * - Only on Bora
- - Only on Golf
- *** - For vehicles from August 1998
- - For vehicles up to July 1998 only

ws = white
 sw = black
 ro = red
 br = brown
 gn = green
 bl = blue
 gr = grey
 li = lilac
 ge = yellow
 or = orange

